

# CENTRIFUGAL PUMPS

## FPE Series

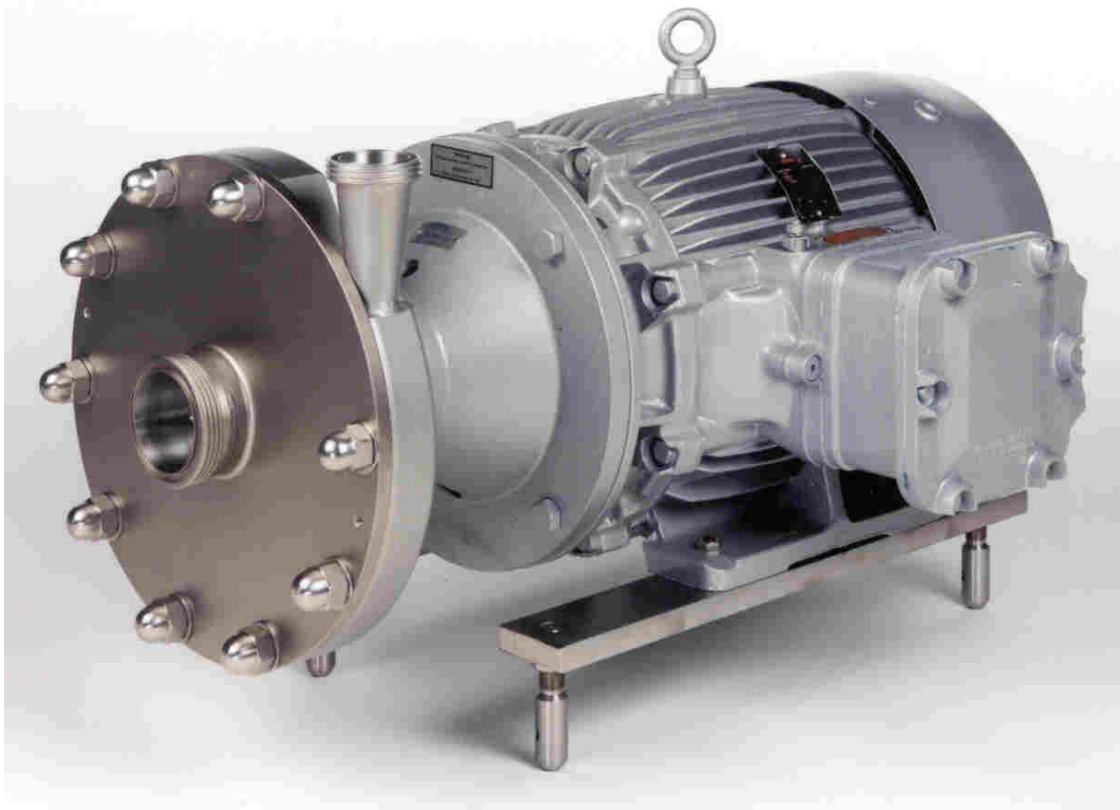

**Model :**

**Model No.:**

## Table of Contents

	<b>Page</b>
<b>1. Maintenance</b>	<b>1</b>
1.1. Disassembly	1
1.1.1. General	1
1.1.2. Impeller	1
1.1.3. Complete disassembly	1
1.2. Assembly	2
1.2.1 General	2
1.2.1.1 Setting the gap	2
1.2.1.2 Screw tightening torque	3
1.2.2 FPE assembly	3
1.2.3 FPE with double shaft seal	5
1.3. Highly polished surfaces	6
1.4. FRISTAM worldwide	7

## 1. Maintenance

### 1.1 Disassembly

#### 1.1.1 General



- Disconnect the pump from the power supply so that it is de-energised.
- If fitted, close the shut-off valve in the suction pipe and discharge pipe.
- Undo the suction/discharge connections and remove the pump from the system.



- In the case of dangerous pumping media, legal and works safety directions must be observed.

#### 1.1.2 Impeller and shaft seal

- Unscrew the cover and drain the pump, clean it, if necessary
- Undo the impeller nut
- Pull off the impeller from the shaft and remove the feather key
- Carefully dismantle the shaft seal parts in accordance with the order-related documentation

#### 1.1.3 Complete disassembly

- Undo the clamping screw resp. hex-screws between casing and lantern (only for 1051/2, 1151/2, 1231/2, 1251/2, 101/102 – 200, 101/102 – 250)
- Pull off the casing
- Undo the screws between the motor flange and clamping disc / lantern
- Pull off the clamping disc / lantern
- Undo the screws of the shrink-fit ring
- Release the tensioning rings from the clamping ring
- Pull off the pump's hollow shaft from the motor shaft
- Pull off the shrink-fit ring from the pump's hollow shaft

## 1.2. Assembly

### 1.2.1. General

Before assembling the pump, the following has to be done:

- The parts have to be cleaned
- The sealing area has to be cleaned
- All parts have to be checked for precision fit and, if necessary, reworked, with the exception of the sliding surfaces of the shaft seal
- Worn parts have to be replaced
- O-rings and gaskets always have to be replaced before assembly

#### 1.2.1.1 Setting the gap

The gap size of the pump must be reset in accordance with Tab 1.

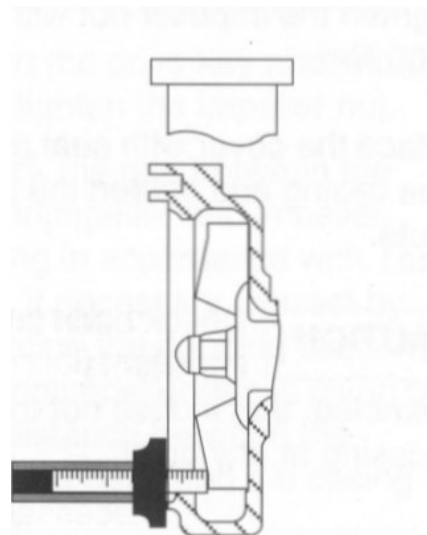
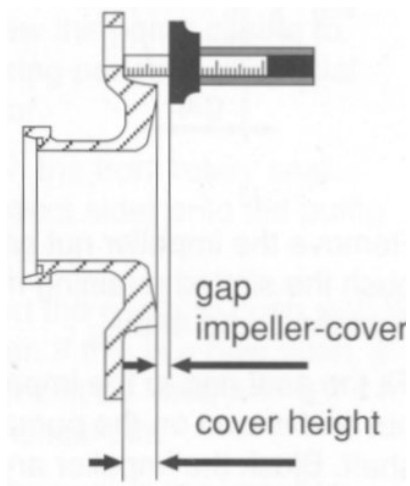
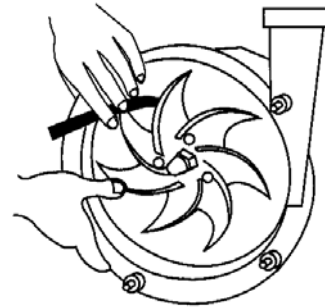

Pump Type	Axial gap between impeller and cover	Axial gap between impeller and casing
FPE 711 / 2 FPE 721 / 2 FPE 741 / 2 FPE 3401 / 2 FPE 3521 / 2	0.5 mm	0.5 mm
FPE 3531 / 2	0.5 mm	1.0 mm
FPE 3541 / 2 FPE 3551 / 2 FPE 3451 / 2 FPE 751 / 2	1.0 mm	1.0 mm
FPE 1051 / 2	0.7 mm	0.8 mm
FPE 1151 / 2	2.0 mm	2.0 mm
FPE 1231 / 2 FPE 1251 / 2	1.0 mm	1.5 mm
FPE 101 / 102 - 200 FPE 101 / 102 - 250	0.5 mm	1.2 mm

Tab. 1 : Gap sizes

### 1.2.1.2 Screw tightening torque

The screw tightening torque in the tables below must be complied with

	M 6	M 8	M 10	M 12	M 16	M20
Nm	10	25	49	85	210	420

Tab. 2: Class 8.8 steel screws

	M 8	M 8	M10	M 12	M 16	M20
Nm	7,3	17,5	35	60	144	281

Tab. 3: Stainless steel screws A2-70 and A4-70

### 1.2.2 Pump assembly

1. Remove the feather key from the motor shaft.
2. Degrease the motor shaft and bore of the hollow shaft.
3. Insert half feather key into the motor shaft (only for bigger motors above 30 kW)
4. Seal the motor shaft around the shaft shoulder with a sealing gel (e.g. Stucarit sealing gel 309).
5. Push the hollow shaft with shrink-fit ring onto the motor shaft up to the shaft shoulder.
6. Tighten the hexagon socket screws of the shrink-fit ring in diagonally opposite sequence (see Tab. 4).



### 1.2.3 Pump with double shaft seal

1. Remove the feather key from the motor shaft.
2. Degrease the motor shaft and bore of the hollow shaft

**Caution:** Radial gasket to be fitted onto a speedy – sleeve

3. Use a piece of pipe (length between 120 to 150 mm) to push the sleeve onto the shaft.  
Inner diameter of pipe 23 mm (for 22 mm shaft), 36mm (for 35mm shaft)

**Caution:** For 22 mm shaft only: Sealing cover with radial gasket to be fitted to pump housing. Flushing pipes in vertical direction, then threaded pins to be fixed manually.

4. Insert half feather key into the motor shaft (only for bigger motors above 30kW)
5. Seal the motor shaft around the shaft shoulder with sealing gel (e.g. Stucarit sealing gel 309).
6. Push the hollow shaft with shrink-fit ring onto the motor shaft up the shaft shoulder.
7. Tighten the hexagon socket screws of the shrink-fit ring in diagonally opposite sequence (see Tab. 4).
8. Check the hollow shaft for concentricity and align.  
Concentricity tolerance of   max. 0.06 mm for motors below 30 kW  
  max 0.08 mm for motors above 30 kW

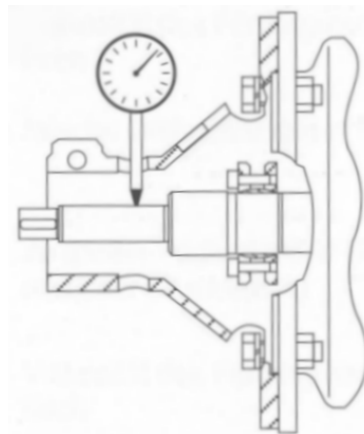

9. Screw the clamping disc / lantern to the motor flange.
10. Insert the shaft seal housing or stationary ring with O-ring into the pump casing and secure (in accordance with the order-related documentation).

11. Screw pump casing and clamping disc / lantern together so as to be fingertight.
12. Flushing pipes to screw into the sealing cover to be sealed with sealing paste.
13. Fit the front seal set of the shaft seal. Cut the Nylon lock ring and put it into the prepared groove behind the thread of the shaft.
14. Insert the O-ring into the impeller nut. Push the impeller on to the pump shaft. Secure the impeller against twisting and tighten the impeller nut with 100 Nm.
15. Set the gap size of the cover, impeller and casing by shifting the pump casing within the clamped joint, resp. measure the gap size and adjust by fitting shims between casing and lantern (only for 1051/2, 1151/2, 1231/2, 1251/2, 101/102 – 200, 101/102 – 250) (see Tab. 1: Gap sizes).
16. Tighten the clamping screw with the following tightening torque:
  - M 10 with 45 Nm
  - M 12 with 75 Nmor hex-screws with torque specified.
17. Place the cover with O-ring onto the casing and tighten.

**Caution:** Each time the impeller is assembled, a check must be made to ensure that it does not chafe at any point, and the Nylon lock ring has to be replaced.

### 1.3 Highly polished surfaces

#### **Caution:**

#### **FOR HIGHLY POLISHED SURFACES**

When tightening or untightening the impeller nut please use softer material tool inlets (copper sheet) in order to prevent surface damage.





Fristam Pumpen F. Stamp  
KG (GmbH & Co.)  
Kurt-A.-Koerber-Chaussee 55  
21033 Hamburg (Germany)

Tel.: (0)40 / 7 25 56-0  
Fax: (0)40 / 725 56-166  
info@fristam.de

**Australia**

Fristam Australia Pty.  
Ltd., Boronia

**Austria**

Fristam Pumpen GmbH  
Vienna

**Belgium/Luxembourg**

Fristam N.V.  
Aartselaar

**France**

Pompes Fristam S.A.  
Noisy-le-Sec

**Great Britain**

Fristam Pumps (UK) Ltd.  
Hailsham

**India**

Fristam Pumps (I) Pvt.Ltd  
Pune

**Italy**

Fristam Italia S.r.l.  
Borgo Ticino (NO)

**Japan**

Stamp Pumps of Japan Ltd.  
Tokyo

**Netherlands**

Fristam B.V.  
De Meern

**New Zealand**

Fristam Pumps Ltd.  
Auckland

**Poland**

Fristam Polska Sp.z.o.o.  
Warszawa

**Russia**

Fristam Pumpen R.A.  
Moscow

**Scandinavia**

Fristam Pumper A/S  
Sæby

**South / East Asia**

Fristam Pumpen A.R.  
Singapore

**Switzerland**

Fristam Pumpen AG  
Gossau

**USA / Canada / Mexico / South America**

Fristam Pumps, Inc.  
Middleton, WI