

Scum Skimmer

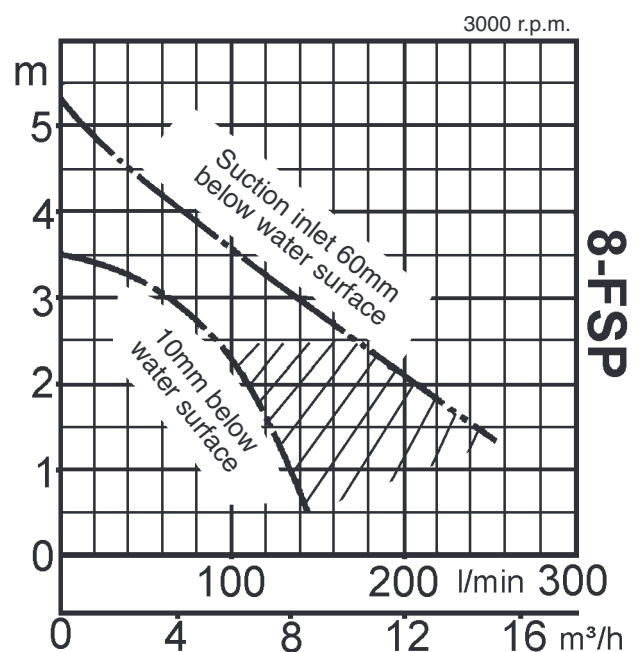

A bypass attached to the discharge opening recycles part of pumped water to the intake to generate a jet flow. An ejector effect produced by the jet flow, generates suction power in the collection cup (Intake).

This guarantees a stable sucking process even if water, air, and suspended matter are drawn in from water surface simultaneously.

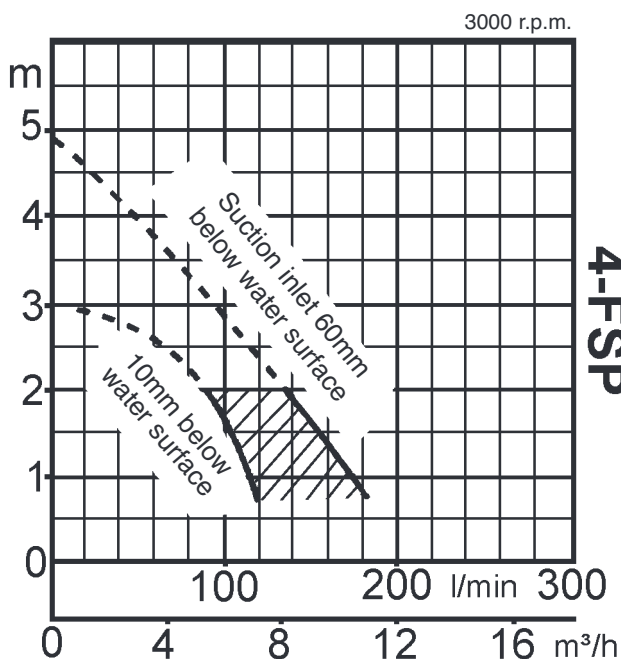

Virtues

- A set of three floats connected by a frame carries the pump. Simple adjustment of the float rods ensures a stable position of the pump inlet cone in relation to the surface of the liquid, in spite of the liquid levels changing (1)
- A powerful jet injector helps the pump suck up water, air, or scum at a constant rate (2)
- These pumps efficiently collect more scum and less supernatant liquid than conventional equivalents (3)
- Use of a flexible hose simplifies installation (4)

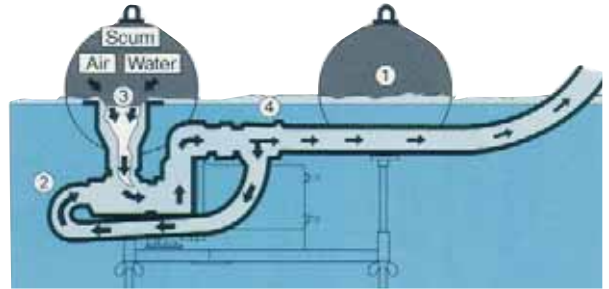

Application

- Collection and return of floating scum at sewage treatment plants
- Collection of suspended solids on water surface
- Collection of supernatant liquid near water surface

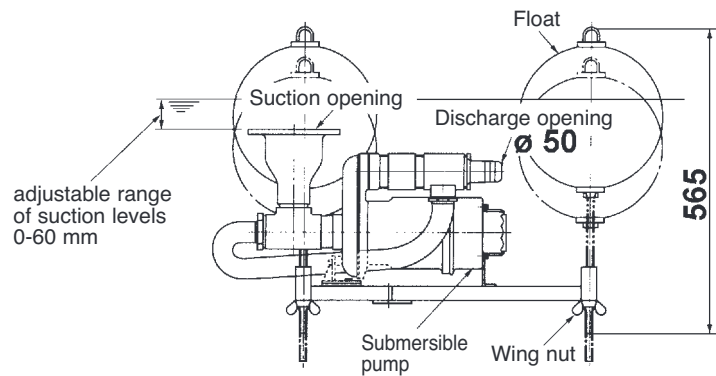
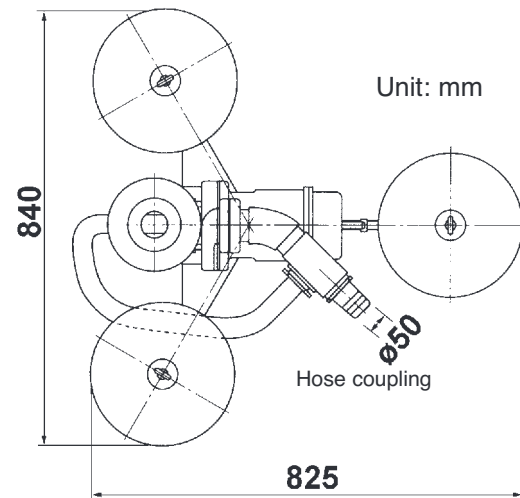

Bore mm	Model	Output kW	Phase	Total Head max.m	Capacity max. l/min	Starting method	Dry Weight kg	Impeller passage dia. mm	Cable m
50	4-FSP	0,4	Three	4,9	180	D.O.L.	36,0	16	10
50	8-FSP	0,75	Three	5,3	255	D.O.L.	37,5	22	10

dry weight of the pump excluding cable

We reserve the right to change specifications and designs herein for improvement without prior notice. Our pumps are for professional use only. In the event that Tsurumi (Europe) GmbH have, in exceptional cases taken over, a manufacturer's warranty, this entitles the end-user to assert remedy free of charge against Tsurumi (Europe) GmbH due to any defect to the product occurring during the guarantee period (see below), also then when the warranty claims against the seller do not or no longer exist. In the event of malfunction, which is attributable to the improper handling by the enduser, no guarantee claim shall arise. Further claims shall not result from the warranty, unless if something to the contrary has explicitly been determined. The decision as to whether remedy is effected by way of replacement or repair shall be at the choice of Tsurumi (Europe) GmbH. The claims shall be time barred after a period of three months after expiry of the guarantee period, however, not before expiry of the warranty period which is valid towards the seller. In the event of doubt, the warranty period shall correspond with the warranty period which is valid between the end-user and his seller.

Tsurumi (Europe) GmbH

Heltorfer Straße 14
D-40472 Düsseldorf
Tel.: +49-211-4179373
Fax: +49-211-4791429
Email: sales@tsurumi-europe.com
www.tsurumi-europe.com

Your Dealer